



众友重工
品质保障 用心智造

匣钵坩埚 成型液压机

CRUCIBLE SAGGER FORMING HYDRAULIC PRESS



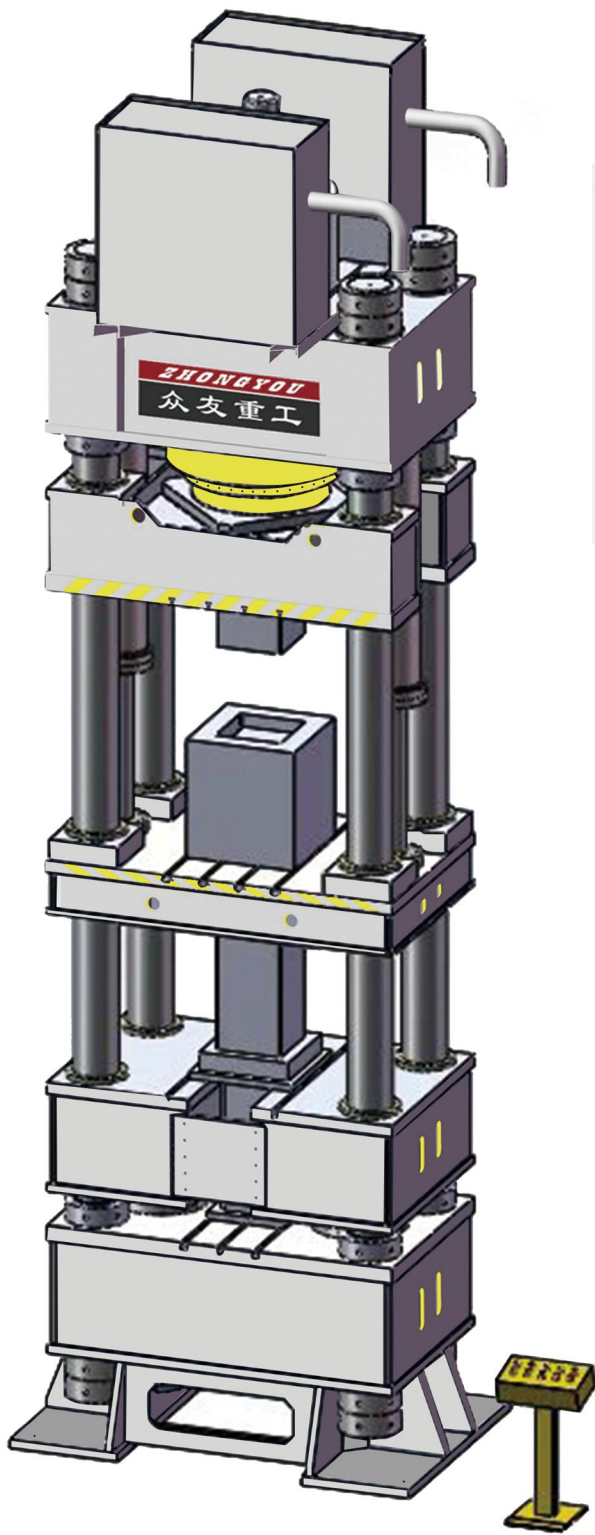

压制产品
Pressed product

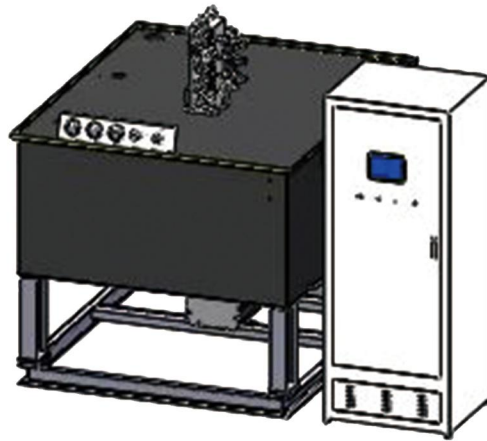

性能特点

匣钵成型液压机，属于粉末成型液压机的一种。从结构上讲，匣钵成型液压机是一种五梁四柱液压机，主油缸为单缸结构，浮动脱模梁与主油缸两侧的辅助油缸相连，通过脱模梁的下沉实现脱模；在实际生产中，需要提前做好下沉式地基，并用地脚螺栓固定好机器的四角。

石墨匣钵是工业匣钵的重要分支，具有电阻系数小、耐高温、耐腐蚀、抗氧化、自润滑、易于精密加工等优点。

Performance characteristics

Sagger forming hydraulic press belongs to a kind of powder unformed hydraulic press. Structurally, the sagger forming hydraulic press is a four-beam and four-column hydraulic press. The main cylinder has a single cylinder structure, and the floating demoulding beams are connected with the auxiliary cylinders on both sides of the main cylinder, and demoulding is realized through the sinking of the demoulding beams.

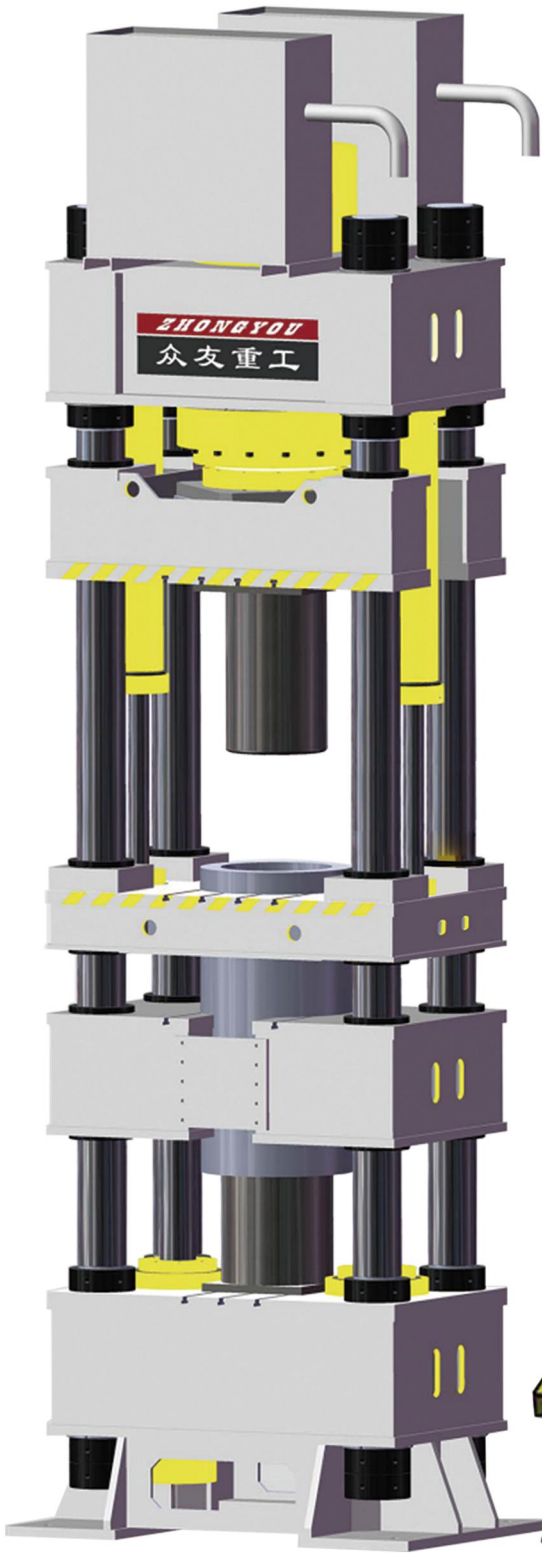

压制产品
Pressed product

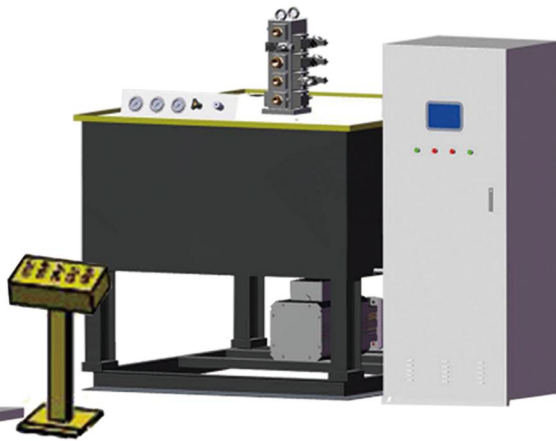

性能特点

坩埚液压机是一种专门用于压制坩埚制品的液压设备。这种机器通常采用双工位结构，一次压制成型，具有高效率、高精度的特点。坩埚液压机主要适用于石墨、耐火黏土、硅石、沥青、焦油和腊石等原料的压制成坩埚配件。

坩埚产品工艺需要热压，专机专用，坩埚成型液压机配合专业的定制模具进行加热，根据客户的配方或用途，成品密度可高达1.7-1.9，压制出来的产品表面光滑，外观精美。

Performance characteristics

The crucible product process requires hot pressing, need a customized press. The crucible forming hydraulic machine is heated with a professional custom mold. According to the customer's formula or application, the finished product density can be as high as 1.7-1.9. The pressed product has a smooth surface and a beautiful appearance.

有限元分析技术的保障

FINITE ELEMENT ANALYSIS TECHNICAL GUARANTEE

上滑块
Upper slider

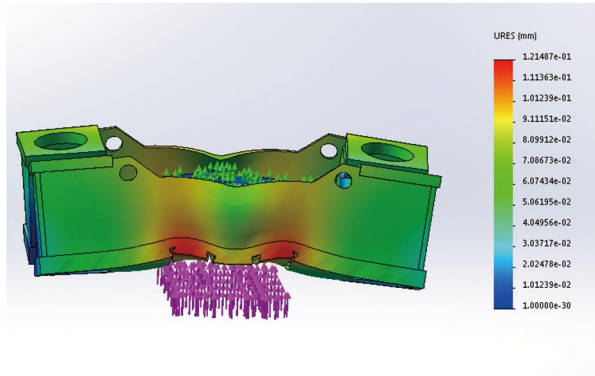

中滑块
Middle slider

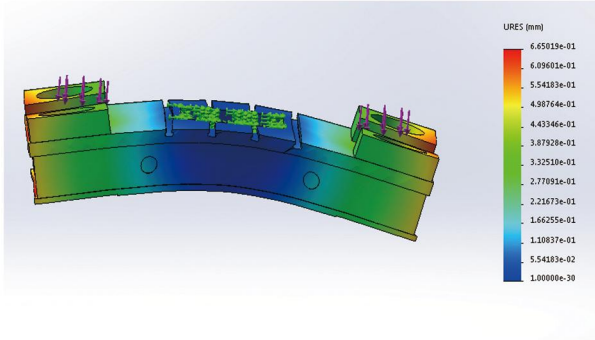

下滑块
Sliding slider

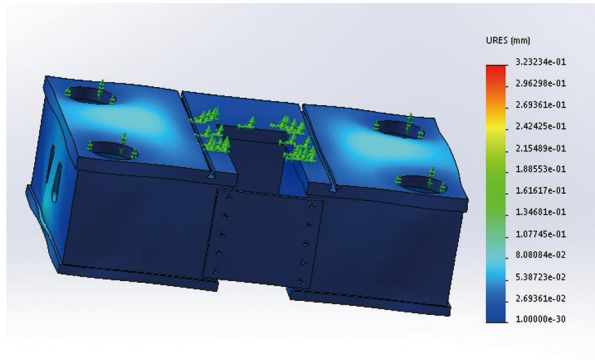

工作台
Working table

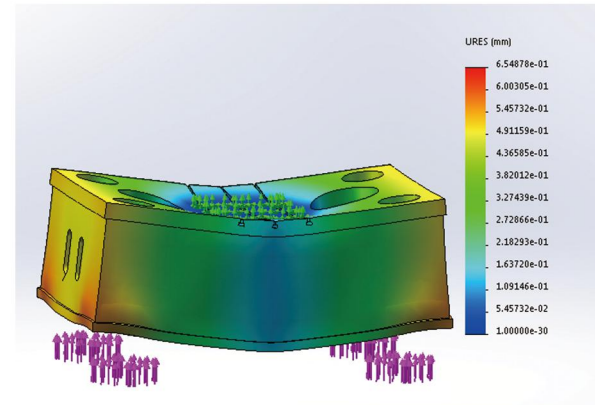

缸帽
Cylinder cap

