



ZHONGYOU

PLASTIC SAND TILE/BRICK HYDRAULIC PRESS

塑料沙子瓦/砖

液压机

山东众友重工机械有限公司

Shandong zhongyou heavy industry machinery co., ltd



四柱机型

四柱塑料沙子瓦/砖液压机采用液压传动原理，通过高压油泵将液压油输送到油缸中，推动活塞杆运动，从而完成对塑料沙子瓦或砖的压制成型。

四柱机型由主机、液压系统、电气控制系统、模具和辅助设备部分组成。其中，主机包括油缸、工作台和立柱等部件；液压系统负责提供压制所需的液压油；电气控制系统则负责控制整个液压机的运行。

四柱机型具有压力大、压制力稳定、操作方便等特点。同时，该液压机采用四柱导向，能够保证产品在压制过程中不偏移，提高产品的质量和合格率。此外，该液压机还具有高效、节能、环保等优点，能够满足大规模生产的需要。

Four-column models

Four-column plastic sand tile/brick hydraulic press adopts hydraulic transmission principle, through the high-pressure oil pump to deliver the hydraulic oil to the oil cylinder, push the piston rod movement, so as to complete the plastic sand tile or brick pressing moulding.

The four-column model consists of main machine, hydraulic system, electrical control system, mould and auxiliary equipment. Among them, the main machine includes oil cylinder, working table and column and other parts; the hydraulic system is responsible for providing the hydraulic oil needed for pressing; the electrical control system is responsible for controlling the operation of the whole hydraulic press.

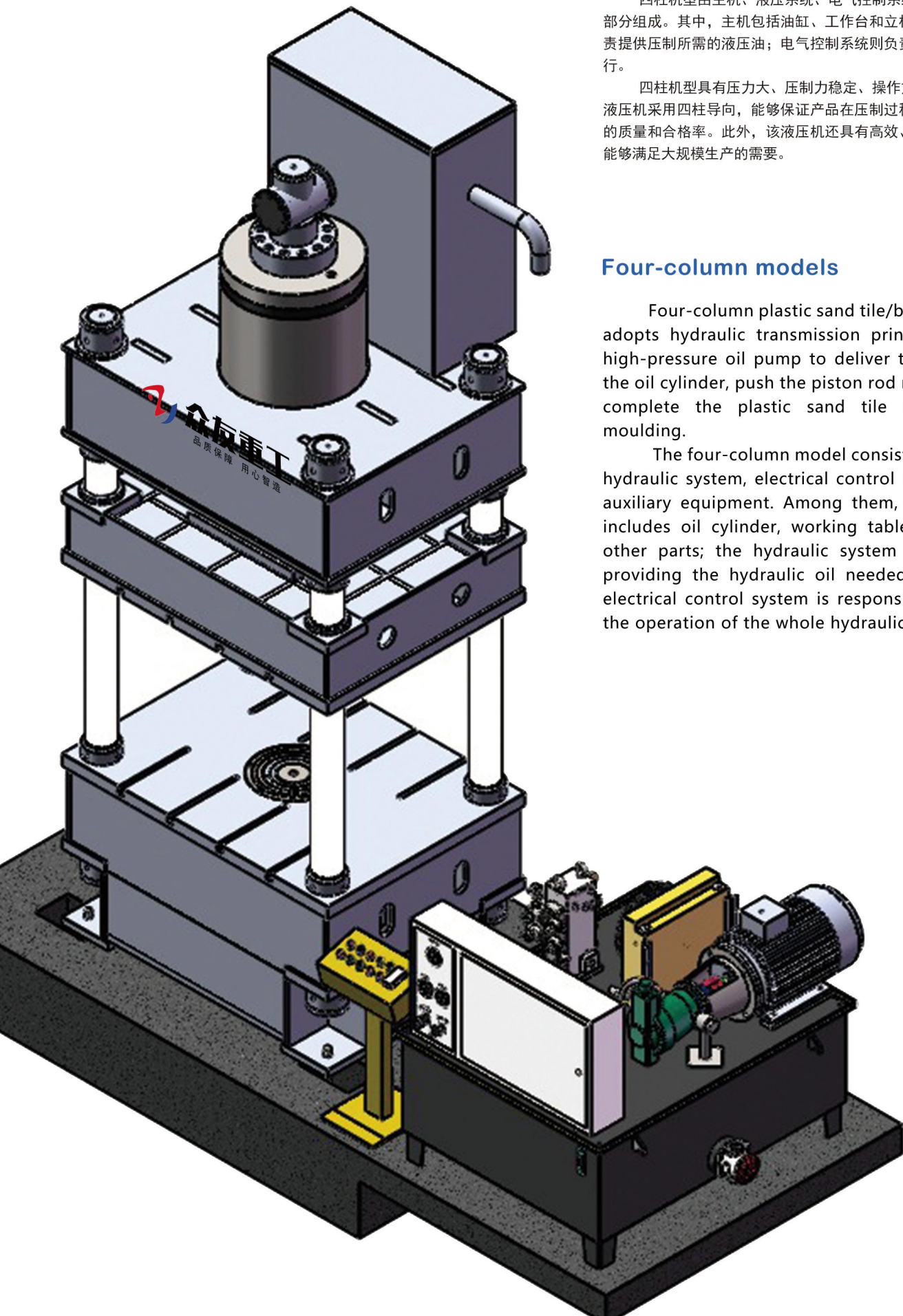

框式机型

框式塑料沙子瓦/砖压机采用液压传动原理，通过高压油泵将液压油输送到油缸中，推动活塞杆运动，从而完成对塑料沙子瓦或砖的压制成型。与四柱液压机不同的是，框式液压机的油缸和活塞杆通常位于一个封闭的框架内，以提供更好的稳定性和导向性。框式机型由主机、液压系统、电气控制系统、模具和辅助设备部分组成。其中，主机包括油缸、工作台和框架等部件；液压系统负责提供压制所需的液压油；电气控制系统则负责控制整个液压机的运行。

框式机型具有结构紧凑、操作方便、制品种类多等特点。由于采用了封闭式框架设计，该液压机能够提供更好的稳定性和导向性，从而提高了产品的质量和合格率。此外，该液压机通常具有较大的压制力，能够满足不同规格和厚度的塑料沙子瓦或砖的生产需求。

框式机型广泛应用于建筑、装修等领域，可用于生产各种类型的塑料沙子瓦、瓷砖、板材等制品。由于其结构紧凑、操作方便等特点，框式塑料沙子瓦/砖压机也适用于空间有限的生产环境。

Frame type

The frame-type model is characterised by compact structure, easy operation and a wide range of products. Due to the closed frame design, this hydraulic press can provide better stability and guidance, which improves the quality and pass rate of the products. In addition, this hydraulic press usually has a large pressing force, which can meet the production needs of plastic sand tiles or bricks with different specifications and thicknesses.

The frame type model is widely used in construction and decoration fields, and can be used to produce various types of plastic sand tiles, tiles, plates and other products. Due to its compact structure, easy operation and other features, the frame type plastic sand tile/brick hydraulic press is also suitable for the production environment with limited space.

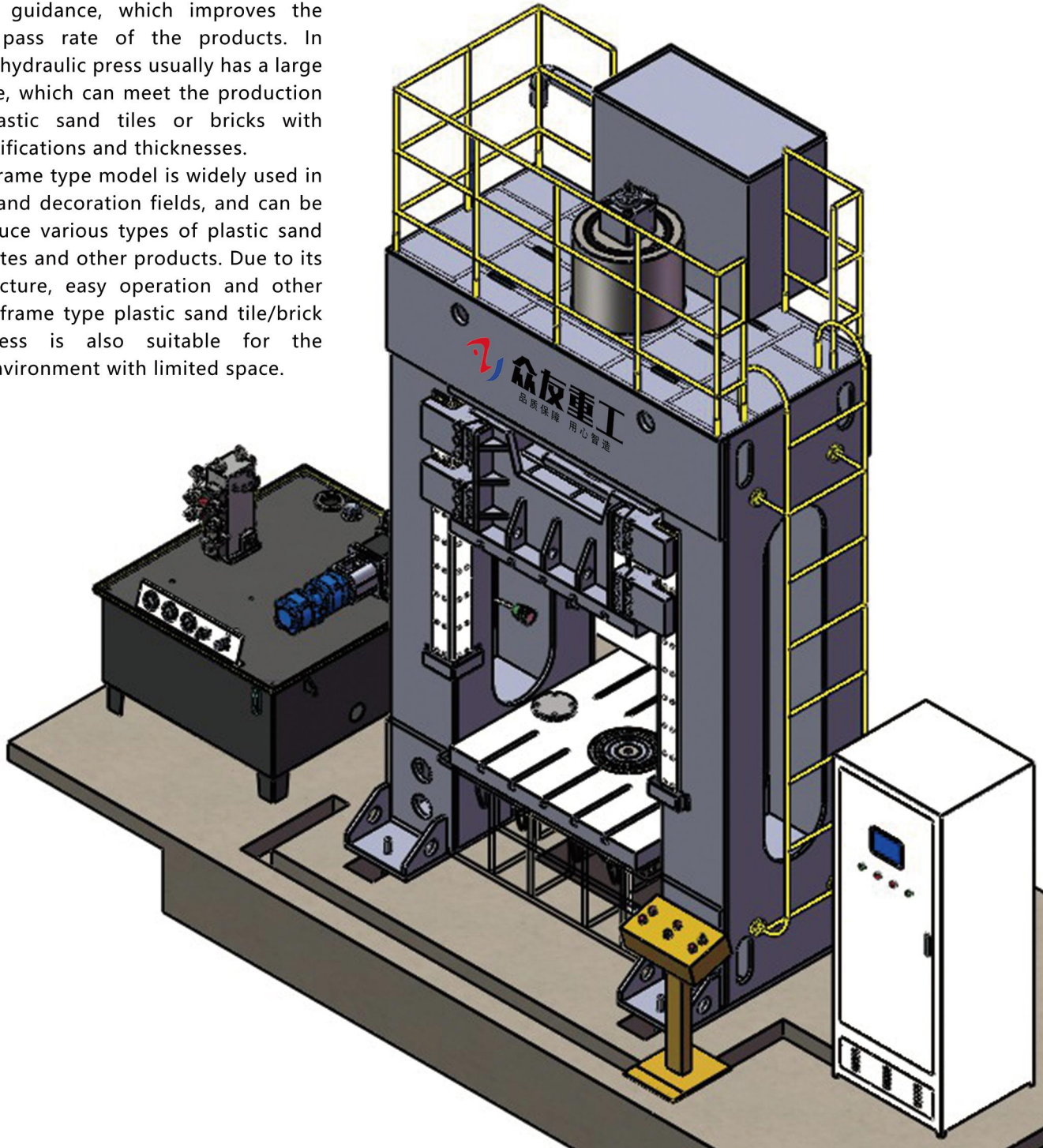

压制产品

Pressed product

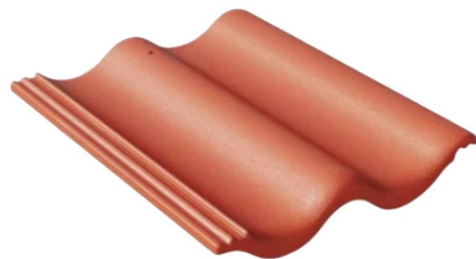
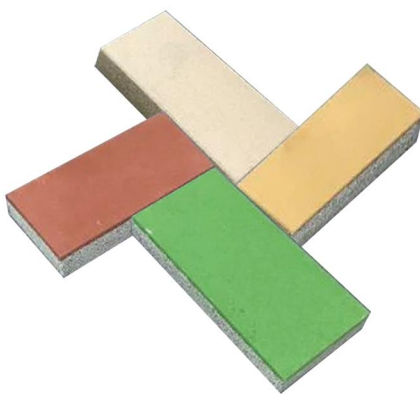
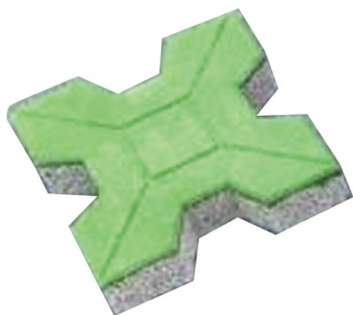

压制工艺流程

Pressing process flow



原材料
Raw material



粉碎机
Pulverizer



PET塑性材料
PET plastic material



成品
End product



液压机
Hydropress



挤出机
Extruder